



Application

- Can be used to transfer liquids with light corrosive, requirement for health and containing impurities, etc.
- Suitable for industrial & domestic sewage system, food & beverage processing, farming, pumping water from river and lake, etc.
- Can be used at full head without overloading motor.

Pump

- AISI 304 pump body
- AISI 304 shaft
- Liquid temperature: -15°C ~ +80°C
- Liquid PH value: 5 - 9
- Max. solid diameter: 19 mm

Motor

- Motor with copper winding
- Built-in thermal protector for single phase motor
- Insulation class: F
- Protection class: IPX4
- Max. temperature: +40°C

Identification Codes

ABK 200 D

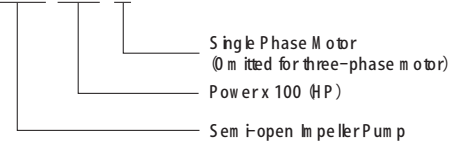

Technical Data

MODEL		POWER		Q (m³/h)													Impeller passage (mm)
Single Phase	Three Phase	kW	HP	1.2	2.4	3.6	4.8	6	12	18	24	33	42	48	57	66	
ABK50D	ABK50	0.37	0.5	11.6	10.5	9.7	8.7	7.5	-	-	-	-	-	-	-	-	9
ABK100D	ABK100	0.75	1	-	-	-	-	8	7	5	-	-	-	-	-	-	12
ABK120D	ABK120	0.9	1.2	-	-	-	-	11	10	9	-	-	-	-	-	-	12
ABK150D	ABK150	1.1	1.5	-	-	-	-	9.5	8.8	7.8	6.7	5	-	-	-	-	12
ABK200D	ABK200	1.5	2	-	-	-	-	12.7	12	11.2	10	8.3	6.5	-	-	-	16
ABK300D	ABK300	2.2	3	-	-	-	-	15	14	13.5	12.7	11.2	9.8	8.9	7.5	-	16
-	ABK400	3	4	-	-	-	-	17.5	16.8	16	15.2	14	12.5	11.5	9.7	7.5	19

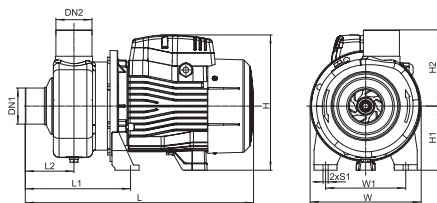

Dimension

Model	Ports		L (mm)	L ₁ (mm)	L ₂ (mm)	H (mm)	H ₁ (mm)	H ₂ (mm)	W (mm)	W ₁ (mm)	S ₁ (mm)
	DN1	DN2									
ABK50(D)	1 1/4"	1"	280	123	50	180	90	106	170	105	9
ABK100(D)	1 1/2"	1 1/2"	332	160	76	212	100	118	170	120	9
ABK120(D)	1 1/2"	1 1/2"	332	160	76	212	100	118	170	120	9
ABK150(D)	2"	2"	400	184	85	235	112	133	195	140	9
ABK200(D)	2"	2"	400	184	85	235	112	133	195	140	9
ABK300(D)	2 1/2"	2"	450	184	85	252	117	133	195	140	9
ABK400	2 1/2"	2"	450	184	85	252	117	133	195	140	9

Hydraulic Performance Curves

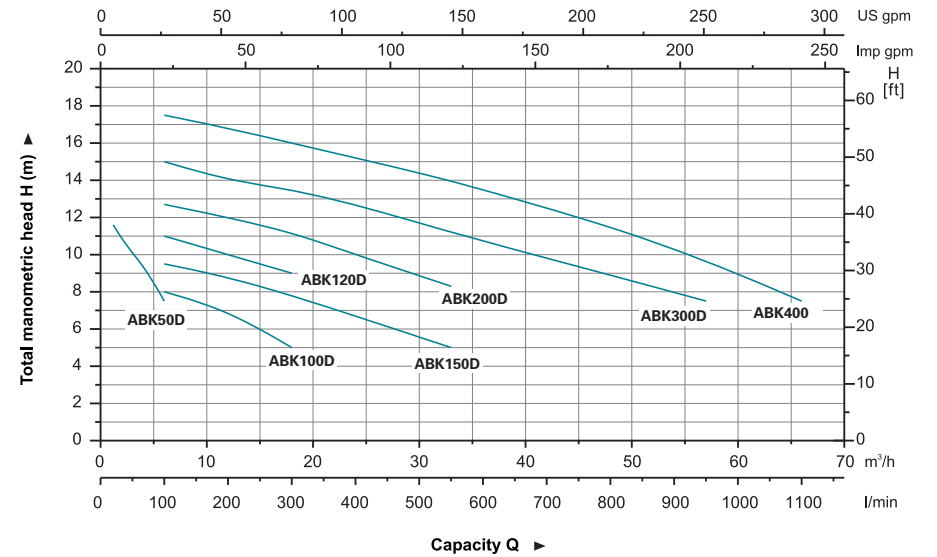

Materials Table

No.	Part	Material
1	Pump body	AISI 304
2	Impeller	AISI 304
3	Mechanical seal	SiC/Carbon
4	Bracket cover	AISI 304
5	Support	ZL102
6	Bearing	
7	Rotor	
8	Stator	
9	Terminal box	PC/ABS
10	Rear cover	ZL102
11	Fan	PP-GF30
12	Fan cover	08F

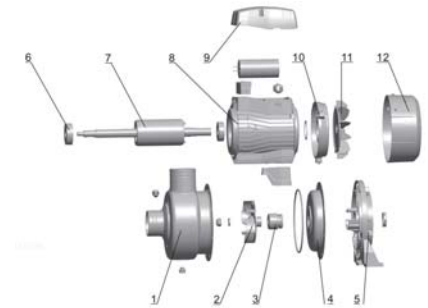

Package Information

Model	GW (Kgs)	L (mm)	W (mm)	H (mm)	Quantity (PCS/20 TEU)
ABK50(D)	6.5	310	190	215	2130
ABK100(D)	9.6	360	200	235	1566
ABK120(D)	10.7	360	200	235	1566
ABK150(D)	14	420	235	265	1032
ABK200(D)	15.7	420	235	265	1032
ABK300(D)	20.7	475	230	275	864
ABK400	21.8	475	230	275	864

