



NEW

POMPE PER ACQUA SPORCA AD ALTA PREVALENZA SEWAGE WATER PUMPS WITH HIGH HEAD



VORTEX E / 23

 Pompe sommergibili adatte alla movimentazione di acque sporche e reflui industriali contenenti corpi solidi o filamentosi. Robusta costruzione. Coperchio, corpo di mandata e supporto in ghisa. Cassa statore in ghisa nel modello VORTEX 1000 E, in acciaio AISI 304 negli altri modelli. Girante monocanale nel modello VORTEX 1000 E, aperta ed arretrata di tipo “vortex” in ghisa negli altri modelli. Doppia tenuta meccanica in carburo di silicio in camera d’olio. Cavo di alimentazione di 10 metri in neoprene H07RNF. Protezione a cura dell’utente. IP 68. Isolamento classe F. Temperatura massima del liquido da pompare 40 °C; pH: 6 – 10; massima densità < 1100 kg/m³.

 Submersible pumps suitable for the pumping of dirty water and industrial effluents containing solid or fibrous parts. Heavy duty construction. Cover, discharge body and footing in cast-iron. Motor case in cast-iron on the model VORTEX 1000 E, in stainless steel AISI 304 on the other models. Mono-channel impeller on the model VORTEX 1000 E, back and open impeller “vortex” type in cast-iron on the other models. Double mechanical seal in silicon carbide in oil chamber. 10 meters supply cable H07RNF. The pump must be protected by a fused remote isolator switch. IP 68. Insulation class F. Max. temperature of pumped liquid 104 °F (40 °C); pH: 6 – 10; max. density: < 1100 kg/m³.

 Pompes submersibles indiquées pour eaux sales avec corps solides ou filamenteux. Particulièrement conseillées pour eaux résiduaires et pour traitement des eaux industrielles. Construction robuste. Couvercle, corps de refoulement et support en fonte. Corps de moteur en fonte dans le modèle VORTEX 1000 E, en acier AISI 304 dans les autres modèles. Roue monocanal dans le modèle VORTEX 1000 E, type « vortex » en fonte dans les autres modèles. Double garniture mécanique en carbure de silicium en chambre d’huile. Câble électrique H07RNF de 10 mètres. Protection par l’usager. Protection IP 68. Isolation classe F. Température max. du liquide pompé 40 °C; pH: 6 – 10; densité max. < 1100 kg/m³.

 Abwasser-Tauchpumpen für Schmutzwasser mit Festkörper. Hergestellt aus hochwertigen und widerstandsfähigen Materialien. Pumpendeckel, Pumpenauslassgehäuse und Sockel aus Grauguss. Statorgehäuse aus Grauguss beim Modell VORTEX 1000 E, aus AISI 304-Stahl bei den anderen Modellen. Einkanaliges Laufrad beim Modell VORTEX 1000 E, “Vortex” Wirbelauftrad aus Grauguss bei den anderen Modellen. “Vortex” Wirbelauftrad aus Grauguss Ölgekühlte Doppel-Gleitringdichtung aus Siliziumkarbid. 10 Meter Kabel H07RNF. Motorvollschutz nach Benutzersorge. IP 68 Schutz. Isol. Klasse F. Max. Temperatur der Flüssigkeit: 40 °C; pH: 6 – 10; max. Dichte < 1100 kg/m³.

Modello Model	Potenza Power		Tensione Voltage	I _n A	Prevalenza - Head (m)								
	HP	kW			4	8	10	12	16	20	24	28	32
	Portata - Capacity (l/min)												
VORTEX 400 E / 23	4.0	3.0	400/50/3	4,6	800	590	455	320					
VORTEX 550 E / 23	5.5	4.0	400/50/3	7,6	998	815	704	600	330				
VORTEX 750 E / 23	7.5	5.5	400/50/3	11,0	1310	1225	1160	1085	855	560	105		
VORTEX 1000 E / 23	10.0	7.5	400/50/3	16,3	2220	2010	1900	1780	1515	1250	950	600	250

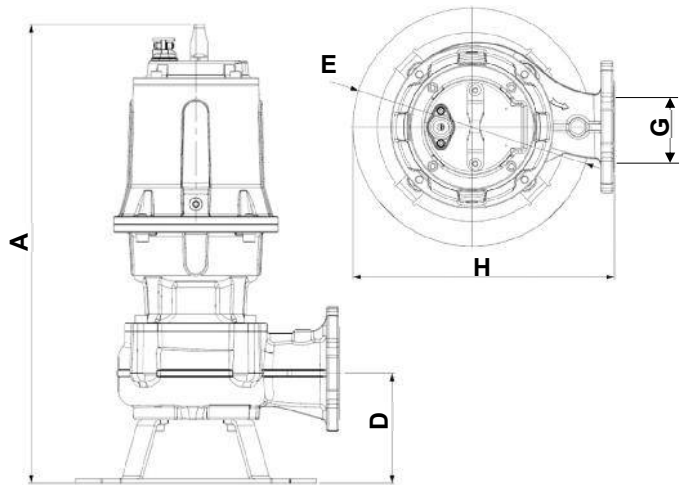
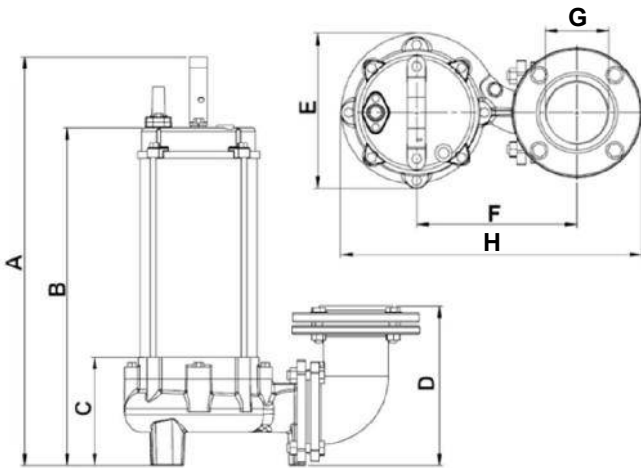
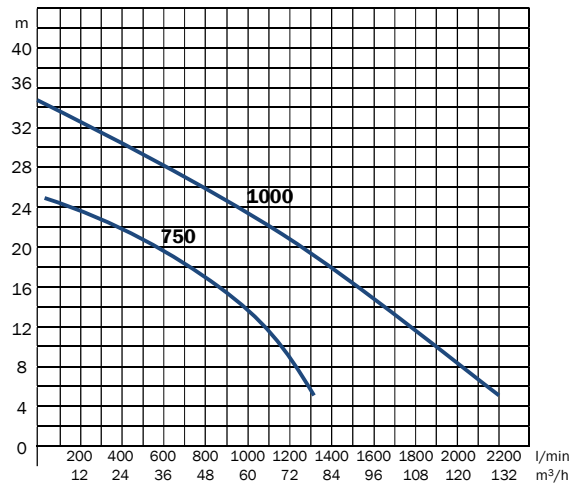
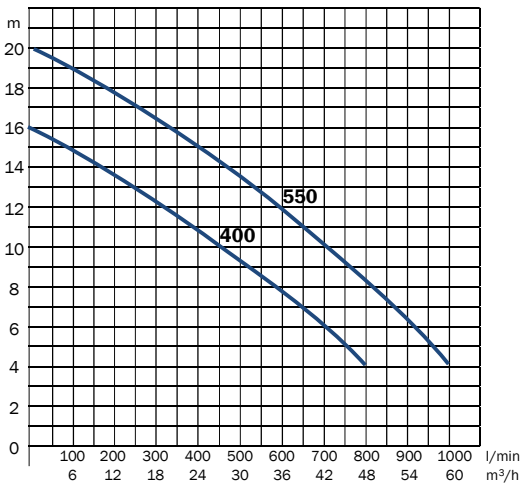

Modello Model	Mandata Discharge	Corpi solidi Solid parts	Dimensioni Dimensions mm								Peso Weight kg
			A	B	C	D	E	F	G	H	
VORTEX 400 E / 23	3" - DN80 vertical	45	530	454	165	165	218	241	3"	401	37
VORTEX 550 E / 23	3" - DN80 vertical	55	576	476	153	225	215	222	3"	417	47
VORTEX 750 E / 23	3" - DN80 vertical	55	619	519	148	250	237	256	3"	468	53
VORTEX 1000 E / 23	3" - DN80 horizontal	55	685	-	-	164	360	-	3"	395	95